

PART NUMBER SCHEME

PART NO.	CONTACTS SUPPLIED	HOUSING COLOR	KEY CONFIGURATION	PART MARKING
SJS830100P	NONE	AMBER	A	SJS830100P
SJS831100P	(8) M39029/57-354			
SJS830101P	NONE	GREEN	B	SJS830101P
SJS831101P	(8) M39029/57-354			
SJS830102P	NONE	YELLOW	C	SJS830102P
SJS831102P	(8) M39029/57-354			

REV	ECN	APP'D
-	7480	JT 4/14/15
A	7619	JT 5/22/15

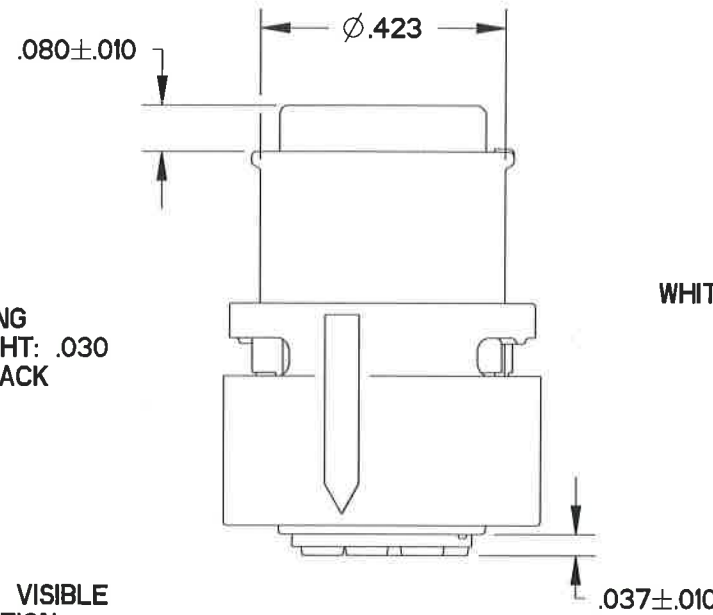
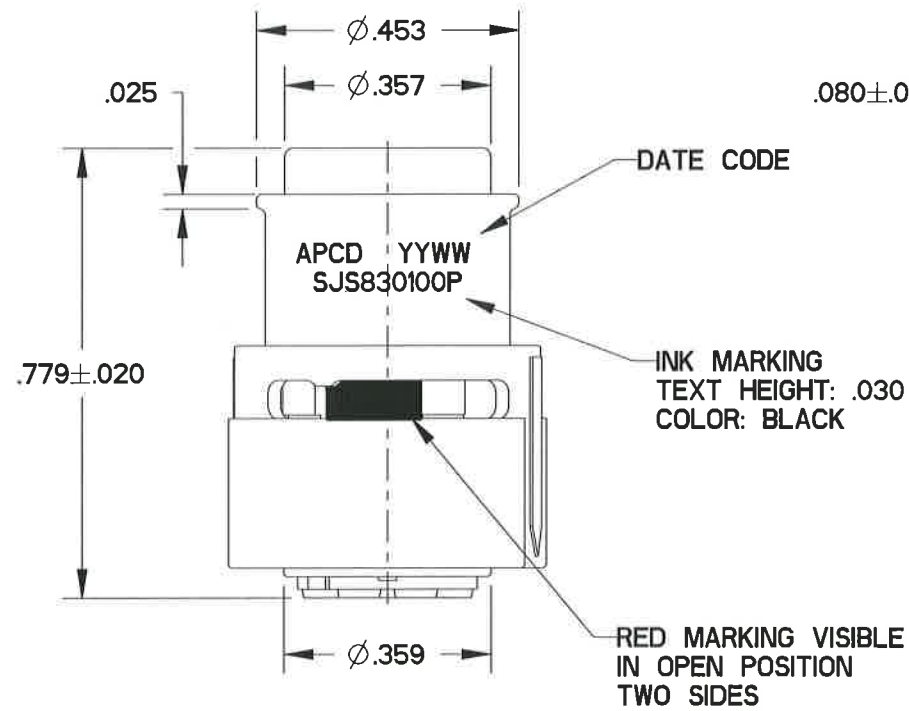
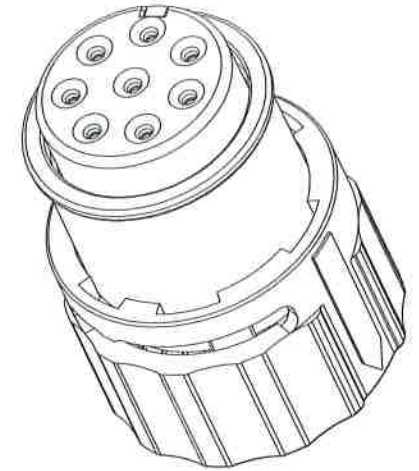
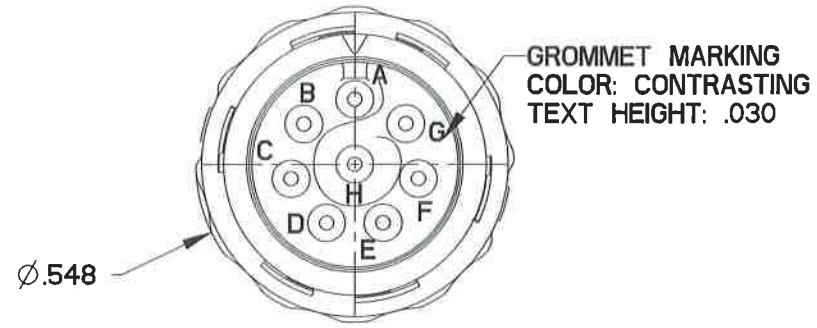

WHITE MARKING TWO SIDES

LOCK

RED MARKING NOT VISIBLE IN CLOSED POSITION TWO SIDES

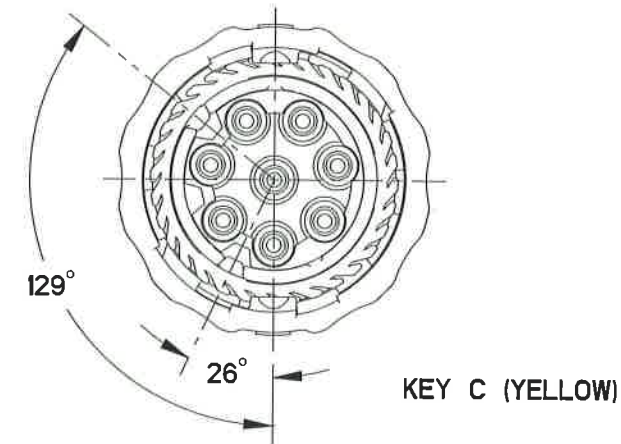
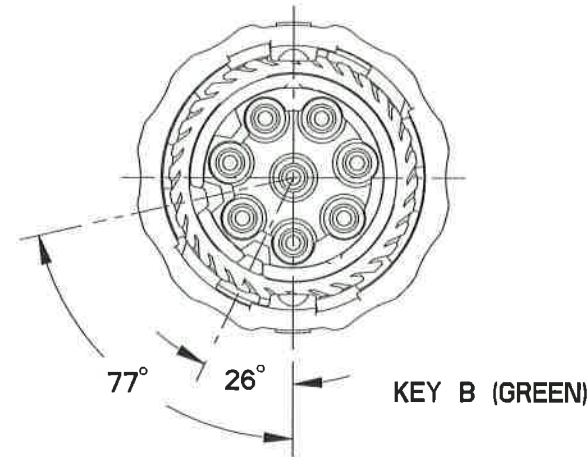
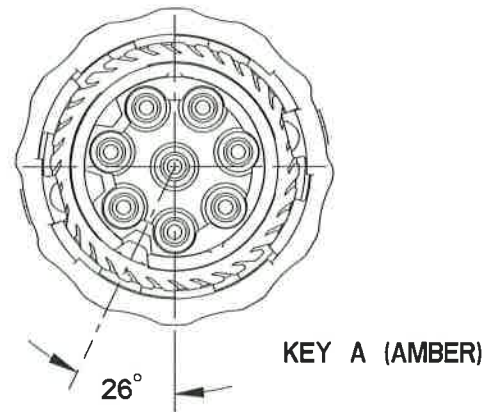

NOTES:

- MATERIALS:  
HOUSING: POLYETHERIMIDE  
CONTACT RETAINER: STAINLESS STEEL  
GROMMET & FACE SEAL: SILICONE RUBBER PER A-A-59588
- FINISH:  
HOUSING: NICKEL, 200 MICROINCHES MINIMUM  
OVER COPPER, 120 MICROINCHES MINIMUM  
EMI SPRING: NICKEL, 100 MICROINCHES MINIMUM
- PART ACCEPTS SOCKET CONTACTS PER: M39029/57-354
- PART MATES WITH SJS83020XP/SJS83120XP & SJS83022XP/SJS83122XP
- WEIGHT: 2.2 GRAMS
- SUPPLIED WITH DUST CAP.

DIMENSIONS ANSI Y14.5M UNITS: INCHES Pro/E FILE	TOLERANCES .XX ±0.01 .XXX ±0.005 ANGLES ±2.0°	PROJECTION 	TITLE <b>Amphenol Pcd</b> SPECIFICATION DRAWING		SIZE <b>B</b>		DWG NO. <b>SJS830100P_C</b>	REV <b>A</b>
			ENGR ANDREW.WANG Mar-05-15	CHKD <i>[Signature]</i> 10/21/15	CODE: 58982	SCALE: 3:1		
ORIGINAL 	THIS DOCUMENT CONTAINS PROPRIETARY INFORMATION WHICH IS THE CONFIDENTIAL PROPERTY OF AMPHENOL PCD INC., BEVERLY, MA		APPD <i>[Signature]</i> 05/22/15					

SJS830100P\_C

SJS830100P\_C